

ROADWORKS LEGEND

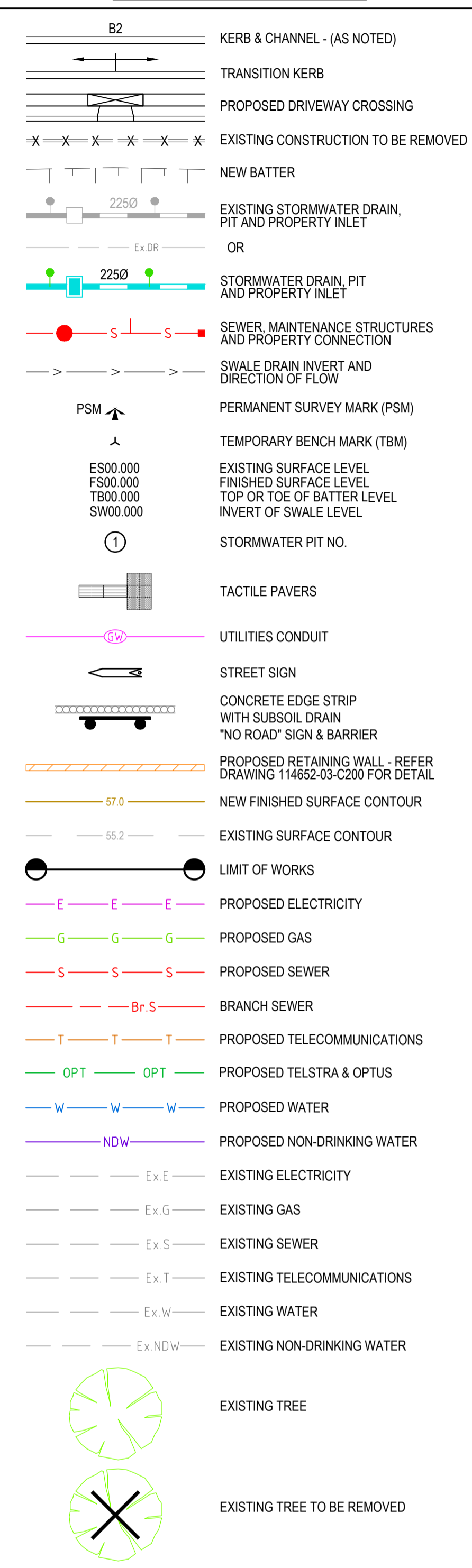

SERVICE OFFSET TABLE

STREET NAME	GAS	NDW	WATER	TELECOMMS	ELECTRICITY
ISLA STREET	2.10 W	2.60 W	3.10 W	1.85 E	2.65 E
BODALLA DRIVE (NORTH-SOUTH)	2.10 W	2.60 W	3.10 W	1.85 E	2.65 E
BODALLA DRIVE (EAST-WEST)	2.10 S	2.60 S	3.10 S	1.85 N	2.65 N
BOUMA ROAD	2.10 N	2.60 N	3.10 N	1.85 S	2.65 S
WOLIN DRIVE (NORTH-SOUTH)	2.10 W	2.60 W	3.10 W	1.85 E	2.65 E
WOLIN DRIVE (EAST-WEST)	2.10 N	2.60 N	3.10 N	1.85 S	2.65 S
KERRIGAN STREET	2.10 W	2.60 W	3.10 W	1.85 E	2.65 E
KOMODO DRIVE	2.10 E	2.60 E	3.10 E	1.85 W	2.65 W

NOTE: OFFSETS SHOWN ARE IN METRES (m)

TREE OFFSET TABLE

STREET NAME	TREE	TREE
ISLA STREET	3.00 W	2.80 E
BODALLA DRIVE (NORTH-SOUTH)	3.00 W	2.80 E
BODALLA DRIVE (EAST-WEST)	3.00 S	2.80 N
BOUMA ROAD	3.00 N	2.80 S
WOLIN DRIVE (NORTH-SOUTH)	3.00 W	2.80 E
WOLIN DRIVE (EAST-WEST)	3.00 N	2.80 S
KERRIGAN STREET	3.00 W	2.80 E
KOMODO DRIVE	3.00 E	2.80 W

NOTE: OFFSETS SHOWN ARE IN METRES (m)

EARTHWORKS LEGEND

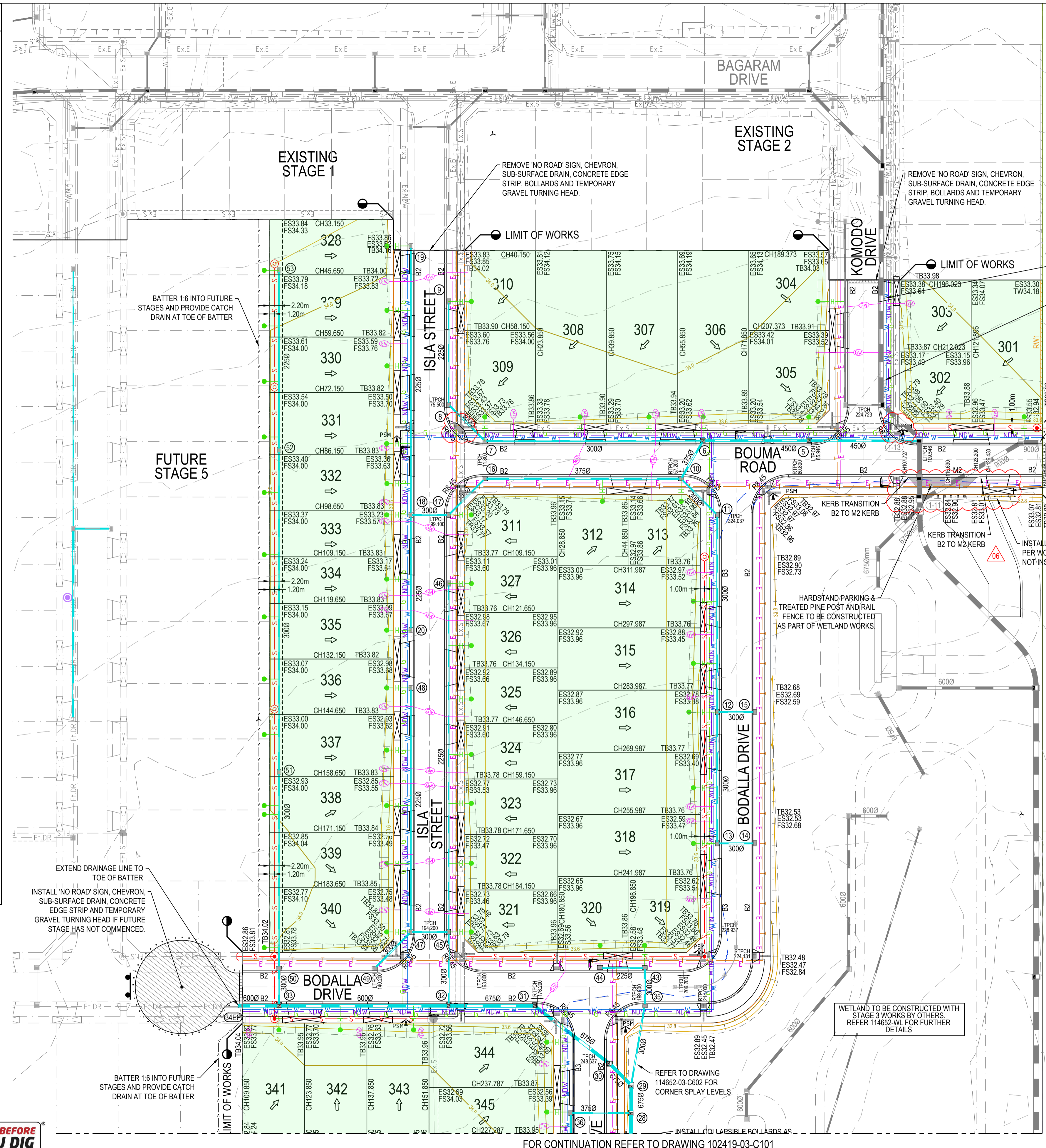
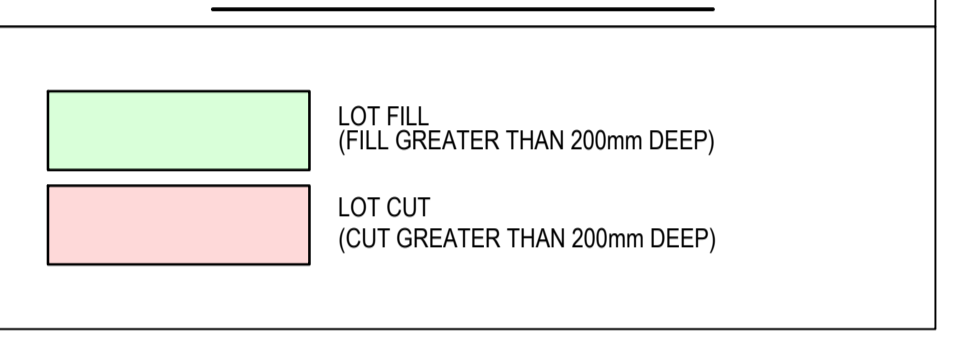

WARNING PROPOSED SERVICES

THE LOCATION AND EXTENT OF PROPOSED SERVICES IS INDICATIVE ONLY AND ARE NOT TO BE USED FOR CONSTRUCTION. REFER TO AUTHORISED DOCUMENTATION BY RELEVANT AUTHORITY FOR CONSTRUCTION DETAILS

WARNING BEWARE OF UNDERGROUND SERVICES

THE LOCATIONS OF UNDERGROUND SERVICES ARE APPROXIMATE ONLY AND THEIR EXACT POSITION SHOULD BE PROVEN ON SITE. NO GUARANTEE IS GIVEN THAT ALL EXISTING SERVICES ARE SHOWN.



REV	DESCRIPTION	BY	APP	DATE
01	CONSTRUCTION ISSUE - RETAINING WALL NOTE ADDED	HE	LG	11.12.17
02	CONSTRUCTION ISSUE - DRAINAGE AMENDMENT	HE	LG	29.03.18
03	CONSTRUCTION ISSUE - GW CONDUITS AMENDED	RT	LG	04.08.18
04	CONSTRUCTION ISSUE - SHEET NUMBERS UPDATED	RT	RP	16.08.18
05	CONSTRUCTION ISSUE - HARD STAND AREA ADDED	RT	RP	04.09.18
06	CONSTRUCTION ISSUE - TGIS, HARD STAND & CROSSOVER AMENDED	RT	CK	21.12.18

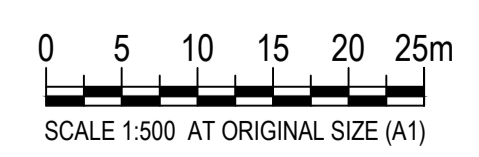

CLIENT
TARNIET PROJECTS PTY LTD
P.O BOX 8023
CAMBERWELL NORTH, VIC. 3124

TITLE
LAYOUT PLAN
SHEET 1 OF 2

PROJECT
GRACE - STAGE 3
605 HOGANS ROAD, TARNEIT
WYNDHAM CITY COUNCIL

STATUS
FOR CONSTRUCTION

DESIGNED LG	DRAWN MG	APPROVED AC	SCALE @ A1 SHOWN	SHEET 3 of 27
PROJECT No 114652-03	DRAWING No C100	REV 06		

COUNCIL REFERENCE NUMBER SDW2291/17
SHEET NUMBER 3 OF 27

DWG FILE: \\114652_03_Hogans Road_Tarneit\62826_3\114652-03-C100-01.dwg - MHPLOT TIME: 21 Dec 2018, 10:48am